

SPRINT



SINGLE LEVER ROUND SHOWER MIXER WITH N-BOX

PRODUCT ID
D050112

FEATURES

- Brass & Zinc Alloy
- Chrome Finish

REMARKS

- Inside Nominal Diameter: G ½
- Applicable inlet pressure: 0.05Mpa - 1.0Mpa
- Best reference pressure: 0.3Mpa-0.6Mpa
- Applicable temperature: <90°C
- Package: Neutral Packing
- PCS/ CTN: 8pcs
- CBM/CTN: 0.09m³
- G.W. / CTN: 12.20kg

WARRANTY

- ROCELL BATHWARE guarantees all its Chrome plated ranges of mixers and taps for a period of 5 years from the date of purchase against defect of work or materials, except for the electronic parts and the internal components such as ceramic cartridges, headworks and thermostatic cartridges which are guaranteed for a period of 2 years.

The guarantee is only offered when products are installed and cared for in line with proper fitting and maintenance methods.

TECHNICAL DRAWINGS

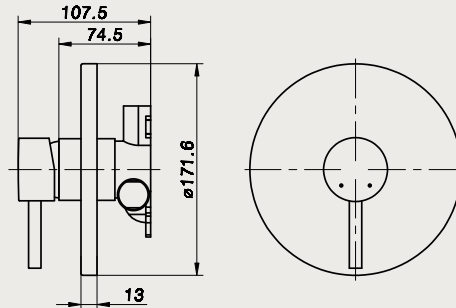

Royal Ceramics Lanka PLC.

No.20, R.A. De Mel Mawatha, Colombo 03, Sri Lanka.

☎ 076 6 223 344 ✉ info@rcl.lk 🌐 www.rocell.com

FOLLOW US



** Dimensions of fixtures are nominal and may vary within the range of tolerance. These measurements are subject to change or cancellation. No responsibility is assumed for use of superseded or voided leaflet.