

ALANTO



SELF-CLOSING TAP

PRODUCT ID

N090043

FEATURES

- Brass Body
- Chrome Finish

REMARKS

- Inside Nominal Diameter: G 1/2
- Applicable inlet pressure: 0.05Mpa - 1.0Mpa
- Best reference pressure: 0.3Mpa-0.6Mpa
- Applicable temperature: <90°C
- Package: Neutral Packing
- PCS/ CTN: 36pcs
- CBM/CTN: 0.06m³
- G.W. / CTN: 23kg

WARRANTY

•

TECHNICAL DRAWINGS

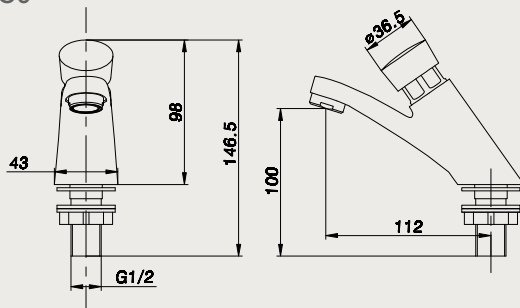

Royal Ceramics Lanka PLC.

No.20, R.A. De Mel Mawatha, Colombo 03, Sri Lanka.

☎ 076 6 223 344 ✉ info@rcl.lk 🌐 www.rocell.com

FOLLOW US



** Dimensions of fixtures are nominal and may vary within the range of tolerance. These measurements are subject to change or cancellation. No responsibility is assumed for use of superseded or voided leaflet.